

DRESS_CODE OUTDOOR

Design gumdesign

S·CAB

art. 2583 GLAM

lounge armchair / chaise-longue /
Lounge-Sessel / sillón lounge

art. 2581 SMART

lounge armchair / chaise-longue /
Lounge-Sessel / sillón lounge



La nuova seduta DRESS_CODE si ispira ai canoni della moda sartoriale, giocando con gli abbinamenti di colori, tra struttura e seduta, con le trame dei tessuti per indoor ed outdoor e con la loro lavorazione: oltre al tessuto liscio come un foglio, viene proposta una versione trapuntata a quadrotti. Le trapuntature e le imbottiture sono sia un elemento grafico che fonte di maggiore comfort. Disponibile come accessorio un cuscino poggiatesta rivestito anch'esso in tessuto.

The new DRESS_CODE lounge armchair is inspired by the canons of haute couture, playing with the combinations of colours between structure and seat, with the indoor and outdoor fabrics patterns, and with their upholstery: in addition to the smooth and flat fabric version, there is a quilted version in big squares. The quilting and padding are both an aesthetic element and a source of greater comfort. A headrest cushion is available as an accessory, also with a fabric cover.

La nouvelle chaise-longue DRESS_CODE s'inspire des normes de la mode vestimentaire, en jouant avec les associations de couleurs, entre structure et assise, avec les tissus pour intérieur et extérieur et avec leur fabrication : en plus du tissu lisse comme une feuille, il existe une version capitonnée carrés. Le capitonnage et le rembourrage sont un élément graphique mais qui offre aussi un plus grand confort. Un coussin appui-tête en tissu est également disponible en option.

DRESS_CODE ist von den Kanons der Schneidermode inspiriert und spielt mit den Farbkombinationen zwischen Struktur und Sitz, mit den Texturen von Innen- und Außenstoffen und mit ihrer Verarbeitung: neben dem glatten Stoff wird auch eine quadratisch gesteppte Version angeboten. Die Steppungen und Polsterungen sind sowohl ein grafisches Element als auch eine Quelle für mehr Komfort. Als Zubehör ist ein ebenfalls mit Stoff bezogenes Kopfstützkissen erhältlich.

El nuevo asiento DRESS_CODE se inspira en los cánones de la moda sartorial, jugando con las combinaciones de colores, entre la estructura y el asiento, con las tramas de los tejidos de interior y exterior y con su confección: además del tejido liso como una hoja, se propone también una versión acolchada en cuadros. Los acolchados y los tapizados son tanto un elemento gráfico como una fuente de mayor comodidad. Como accesorio, hay disponible un cojín para el reposacabezas también en tejido.

TELAIO
FRAME
CHÂSSIS
RAHMEN
MARCO

Struttura in acciaio tubolare Ø 16 mm
Tubular steel structure Ø 16 mm
Structure en acier tubulaire Ø 16 mm
Gestell aus Stahlrohr Ø 16 mm
Estructura de acero tubular Ø 16 mm

FINITURE
FINISHES
FINITIONS
FINISH
ACABADOS



BRACCIOLO Ø 40 mm
ARMREST Ø 40 mm
ACCOUDOIR Ø 40 mm
ARMLEHNE Ø 40 mm
REPOSABRAZOS Ø 40 mm

 iroko certificato FSC®
FSC® certified iroko
iroko certifié FSC®
iroko, FSC®- zertifiziert
iroko certificada FSC®

TELO TESSUTO
SOLO PER ART. 2581
FABRIC CLOTH
ONLY FOR ART. 2581
TOILE EN TISSU
UNIQUEMENT POUR ART. 2581
STOFFBEZUG
NUR FÜR ART. 2581
TELA TEJIDO
SOLO PARA EL ART. 2581



LIMONTA | INTERIORE

S·CAB

Made in Italy — s-cab.it

SEDE/HEADQUARTERS
Via G. Monauni, 12
25030 Coccaglio (BS) Italy

DIVISIONE COMMERCIALE ITALIA
Ph +39 030 7718.760/765/770/775
e-mail: italia@s-cab.it

EXPORT DEPARTMENT
Ph +39 030 7718.715/720/725/726
e-mail: export@s-cab.it

EN: Ogni modello originale S·CAB è protetto da brevetti di forma e da diritti di esclusiva. Misure e colori sono puramente indicativi. All original S·CAB models are covered by shape patents and exclusive rights. Measurements and colours shown are approximatives.
FR: Tous les modèles originaux S·CAB sont protégés par des brevets de forme et des droits d'exclusivité. Les mesures et les couleurs sont purement indicatives. DE: Jedes Modell original S·CAB ist durch Formpatente und Exklusivrechte geschützt.
ES: Cada modelo original S·CAB está protegido por patentes de forma y derechos exclusivos. Medidas y colores son meramente indicativos.

DRESS_CODE OUTDOOR

Design gumdesign

S•CAB

TELO TESSUTO
FABRIC CLOTH
TOILE EN TISSU
STOFFBEZUG
TELA TEJIDO



A3 C8



A3 C7



A4 C9



A5 D0

Corji

TELO TESSUTO
FABRIC CLOTH
TOILE EN TISSU
STOFFBEZUG
TELA TEJIDO



S6 C5



S7 C6

sunbrella

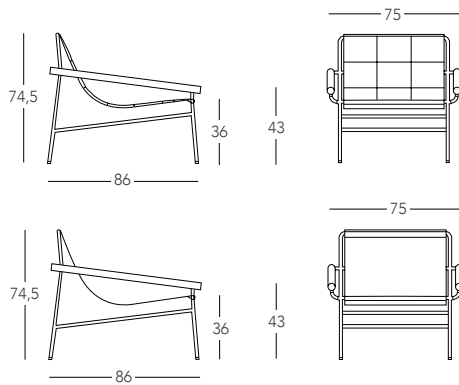

ART. 2583 GLAM



1
pcs



11,5
kg

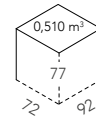

ART. 2581 SMART



1
pcs



11,2
kg

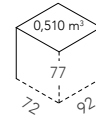

TELO DI RICAMBIO
SPARE CLOTH
TOILE DE RECHANGE
ERSATZBEZUG
TELA DE RECAMBIO

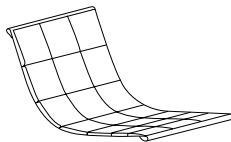

ART. 1603



1
pcs



1,1
kg

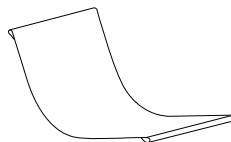
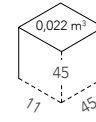

ART. 1602



1
pcs



0,9
kg

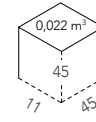

ACCESSORI
FITTINGS
ACCESSOIRES
ZUBEHÖR
ACCESORIOS

ART. 1560 cuscino poggiatesta rettangolare

rectangular headrest cushion / coussin appui-tête rectangulaire /
Kopfstützkissen rechteckig / cojín apoyacabeza rectangular

ART. 1562 copertura protettiva

outdoor cover / housse de protection / Schutzabdeckung / funda protectora

S•CAB

Made in Italy — s-cab.it

SEDE/HEADQUARTERS
Via G. Monauni, 12
25030 Coccaglio (BS) Italy

DIVISIONE COMMERCIALE ITALIA
Ph +39 030 7718.760/765/770/775
e-mail: italia@s-cab.it

EXPORT DEPARTMENT
Ph +39 030 7718.715/720/725/726
e-mail: export@s-cab.it

CERTIFICAZIONI
CERTIFICATIONS
CERTIFICATIONS
ZERTIFIZIERUNGEN
CERTIFICACIONES



Conforme / Compliant with / Conforme à / Entspricht / Conforme
EN 16139:2013



Prodotto certificato FSC® – Prodotto realizzato con legno certificato proveniente da foreste gestite in modo corretto e responsabile
FSC® certified article – The product is manufactured with wood supplied with origin certification from well- and responsibly managed forests.
Produit certifié FSC® – Produit réalisé avec du bois certifié provenant de forêts gérées de manière correcte et responsable.
FSC®-zertifiziertes Produkt – Produkt aus zertifiziertem Holz aus korrekt und verantwortungsvoll bewirtschafteten Wäldern.
Producto certificado FSC® – Producto realizado con madera certificada proveniente de bosques gestionados de manera correcta y responsable.

PREMI
AWARDS
PRIX
AUSZEICHNUNGEN
PREMIOS

**ART. 2583
GLAM OUTDOOR**



Prodotto disassemblabile per un corretto processo di riciclo.
Demountable item for a correct recycling process.
Produit démontable pour un recyclage correct.
Das Produkt kann für einen korrekten Recyclingprozess zerlegt werden.
Producto desmontable para un correcto proceso de reciclaje.

S•CAB

Made in Italy — s-cab.it

SEDE/HEADQUARTERS
Via G. Monauni, 12
25030 Coccaglio (BS) Italy

DIVISIONE COMMERCIALE ITALIA
Ph +39 030 7718.760/765/770/775
e-mail: italia@s-cab.it

EXPORT DEPARTMENT
Ph +39 030 7718.715/720/725/726
e-mail: export@s-cab.it